

# STAINLESS STEEL STERILE FILTER HOUSING - SF

(Sanitary applications)

## DESCRIPTION

SF stainless steel sterile filter housings have been specifically developed for removing of impurities from compressed air <sup>(1)</sup> system. To meet the required compressed air quality appropriate filter element must be installed into filter housing. SF filter housing is also designed for sterilisation. Before use if needed for the application, sterilize the filters.

## APPLICATIONS <sup>(2)</sup>

- Packing industry
- Biotechnology
- Breweries
- Chemical industry
- Diaries
- Fermentation processes
- Food & beverage industry
- Pharmaceutical industry
- Hospitals

<sup>(1)</sup> For any other technical gas please contact us or your local dealer

<sup>(2)</sup> SF process filter housing can be used in variety of applications. For applications not listed please contact us or your local dealer.



## TECHNICAL SPECIFICATION

Operating temperature <sup>(3)</sup>	-20 - 150 °C	-4 - 302 °F
Short duration (15min) temp limit	Up to 200 °C	Up to 392 °F
Operating pressure	0 – 10 bar(g)	0 – 145 psi

<sup>(3)</sup> Actual operating temperature depends on sealing material and type of filter element.

## MATERIALS

Housing material	Stainless steel (quality 1.4404; on request 1.4301)
Sealing	EPDM (Optional FKM or SILICONE)
Housing finishes	Polished down to grade Ra0,8 (externally)
Lubricant	(Optional Shell cassida grease RLS 2)

## MAINTENANCE

Replace filter element at least every 12 months or follow the instructions for specific filter element. Once per year make a visual check of filter housing and make sure there is no visual damage.

**SIZES**

FILTER HOUSING	PIPE SIZE <sup>(4)</sup>	FILTER ELEMENT	FLOW CAPACITY		DIMENSIONS [mm]					VOLUME [l]	WEIGHT [kg]
			[Nm <sup>3</sup> /h]	[scfm]	A	B	C	D	E <sup>(5)</sup>		
SF 0006	DN10	0310-VSF	75	44	220	130	76,1	74	1/8"	0,8	1,6
SF 0009	DN10	0410-VSF	105	62	248	130	76,1	74	1/8"	0,8	1,6
SF 0012	DN15	0420-VSF	150	88	256	128	76,1	78	1/8"	0,9	1,8
SF 0018	DN15	0520-VSF	225	132	288	128	76,1	78	1/8"	0,9	1,8
SF 0032	DN25	0530-VSF	315	185	315	180	114,3	99	1/4"	2,4	3,1
SF 0048	DN32	0730-VSF	600	353	368	181	114,3	90	1/4"	2,9	3,4
SF 0072	DN40	1030-VSF	900	530	449	184	114,3	65	1/4"	4,1	3,6
SF 0108	DN50	1530-VSF	1.260	742	591	188	114,3	110	1/4"	5,1	4,9
SF 0144	DN65	2030-VSF	1.680	989	741	205	139,7	136	1/4"	10,2	8,4
SF 0192	DN80	3030-VSF	2.400	1.413	1014	203	139,7	136	1/4"	12,5	10,2
SF 0432	DN100	3x 2030-VSF	5.040	2.966	1005	410	219,1	183	1/2"	36	44
SF 0576	DN100	3x 3030-VSF	6.720	3.955	1266	410	219,1	183	1/2"	43	45
SF 0768	DN150	4x 3030-VSF	9.600	5.650	1337	480	273	267	1/2"	77	70
SF 1152	DN150	6x 3030-VSF	13.440	7.910	1331	540	323,9	267	1"	110	80
SF 1536	DN200	8x 3030-VSF	17.200	10.124	1496	660	406,4	306	1"	190	200
SF 1920	DN200	10x 3030-VSF	21.120	12.431	1496	660	406,4	306	1"	190	201

Flow capacity at 7 bar(g), 20°C

<sup>(4)</sup> Standard is DIN 32676 pipe connection.

<sup>(5)</sup> Standard is BSP pipe connection.

**PRESSURE EQUIPMENT DIRECTIVE PED 2014/68/EU (Fluid group 2)**

SF 006 - SF 0072	Not required
SF 0108 - SF 0192	Category 1, Module H
SF 0432 - SF 0768	Category 2, Module H
SF 1152 - SF 1920	Category 3, Module H

**PRESSURE EQUIPMENT DIRECTIVE PED 2014/68/EU (Fluid group 1)<sup>(6)</sup>**

SF 0006 - SF 0032	Article 4.3
SF 0048 - SF 0072	Category 1, Module H
SF 0108 - SF 0192	Category 2, Module H
SF 0432 - SF 0768	Category 3, Module H
SF 1152 - SF 1920	Category 4, Module H1

<sup>(6)</sup> Fluid group must be specified in the order, if not standard fluid group 2 is selected.

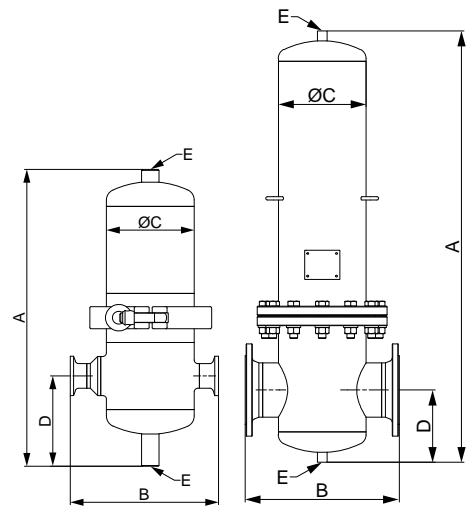

**CORRECTION FACTORS**

To calculate the correct capacity of a given filter based on actual operating conditions, multiply the nominal flow capacity by the appropriate correction factor(s).

CORRECTED CAPACITY = NOMINAL FLOW CAPACITY x C<sub>OP</sub>

**OPERATING PRESSURE**

[bar]	2	3	4	5	6	7	8	9	10
[psi]	29	44	58	72	87	100	115	130	145
C <sub>OP</sub>	0,38	0,5	0,63	0,75	0,88	1	1,13	1,25	1,38

INFORMATION IN THIS DOCUMENT IS SUBJECT TO CHANGE WITHOUT NOTICE

	<p>Our quality management system is certified by BUREAU VERITAS in conformity with ISO 9001:2015 Reg. number: 200285</p>	
---	--	--