

ADSORPTION DRYER

A-DRY 06 - 200

(Heatless regenerated adsorption dryer)

DESCRIPTION

A-DRY adsorption dryers have been designed for continuous separation of water vapour from compressed air thus reducing dew point. Operation of the dryer requires two columns operated alternately. Adsorption takes place under pressure in the first column while the second column regenerates with a portion of already dried compressed air at ambient pressure. Dryers consists from upper and lower control block, controller with LED display and two columns filled with desiccant. Springs in the columns make sure that the desiccant beads will not move during operation. Proven robust design enables efficient and reliable operation, fast installation and simple maintenance.



DRYER RATING ACCORDING TO ISO8573-1

Solid particles ⁽¹⁾	Water ^{(1),(2)}	Oil ⁽¹⁾
2	1-3	1

⁽¹⁾Typical result based on standard configuration and nominal operating conditions.

⁽²⁾Depend on specific design. Class 2 when operated at nominal operating conditions.

TECHNICAL SPECIFICATIONS

Operating pressure	4 – 16 bar(g)	A-DRY 06 to A-DRY 200
Operating temperature	1,5°C to 50°C	
Pressure dew points	-40°C (-25°C, -70 °C)	
Voltage, Frequency	230 V, 50/60 Hz	
Power consumption	<35 W	
Protection class (controller)	IP 65	
Filter (inlet) ⁽³⁾	Super fine coalescing; residual oil cont. <0,01mg/m3; 0,01µm	
Filter (outlet)	Dust filter; 1µm	
Input for stand-by	STANDARD, Open contact 24 VDC	
Dew point dependent control	OPTIONAL (available when dew point sensor is installed)	
Communication	OPTIONAL (available only with ADC 2.0 controller)	
	- Profinet or Modbus (TCP/IP)	
	- Web server	

⁽³⁾ If dryer is supplied without inlet filter compressed air class 1 (ISO 8753-1) for solid particles and oil should be provided to the inlet of the dryer.

MATERIALS

Upper and lower control block	Aluminium (anodised)
Columns	Aluminium, Stainless steel spring and support, polyester needle felt, desiccant
Valves	Brass, aluminium
Check valves	PA
Valve membranes	NBR reinforced with PA fibres
Sealings	NBR
Flexible connection	Nylon
Fittings, Screws, plugs	INOX, brass, steel-zinc plated
Lubricant	Shell cassida grease RLS 2
Outside protection (columns, front/back cover)	Powder paint coated (Epoxy-polyester base)
Desiccant	80% Molecular sieve 4A, 20% Silica gel

SIZES

Model	Connection IN & OUT	Inlet flow [m ³ /h] ⁽⁴⁾	Outlet flow [m ³ /h] ⁽⁵⁾	Height A(A*) [mm]	Width B(B*) [mm]	Width D(D*) [mm]	Depth C(C*) [mm]	Mass [kg]	Vessel Vol ⁽⁶⁾ [l]	Filter
A-DRY 06	G 3/8"	6	4,7	339 (520)	280 (480)	354	100 (130)	10,5	1,30	AAF 0056
A-DRY 12	G 3/8"	12	9,5	573 (715)	280 (480)	354	100 (130)	13,5	2,17	AAF 0056
A-DRY 24	G 3/8"	24	19,0	1041 (1105)	280 (480)	354	100 (130)	19,0	3,89	AAF 0056
A-DRY 36	G 3/8"	36	28,4	1364 (1500)	280 (480)	354	100 (130)	27,5	5,61	AAF 0056
A-DRY 60	G 3/4"	60	47,4	972 (1105)	370 (570)	434	148 (160)	45,0	9,95	AAF 0076
A-DRY 75	G 3/4"	75	59,3	1167 (1300)	370 (570)	434	148 (160)	53,0	12,2	AAF 0076
A-DRY 105	G 3/4"	117	83,0	1567 (1700)	370 (570)	434	148 (160)	70,0	16,6	AAF 0106
A-DRY 150	G 1"	150	118,5	1345 (1440)	440 (725,5)	570	198 (240)	170,5	26,3	AAF 0186
A-DRY 200	G 1"	200	158,0	1538 (1655)	440 (725,5)	570	198 (240)	182,2	31,2	AAF 0186

⁽⁴⁾Refers to 1bar(a) and 20°C at 7 bar operating pressure , inlet temperature 35°C and pressure dew point at outlet -40°C

⁽⁵⁾Outlet flow refers to operation at nominal inlet flow conditions. Outlet flow is given at maximum purge air loss of 21,6%. Average pure air losses are approximately 17,3 % of inlet flow at nominal conditions.

⁽⁶⁾Volume of 1 vessel

PRESSURE EQUIPMENT DIRECTIVE PED 2014/68/EU (Fluid group 2)

A-DRY 06 to A-DRY 200	PED Category 1, Module A
-----------------------	--------------------------

CORRECTION FACTORS

To calculate the correct capacity of a given dryer based on actual operating conditions, multiply the nominal flow capacity by the appropriate correction factor(s).

$$Corrected\ capacity = Nominal\ inlet\ flow\ capacity \times c_{OP} \times c_{OT} \times c_D$$

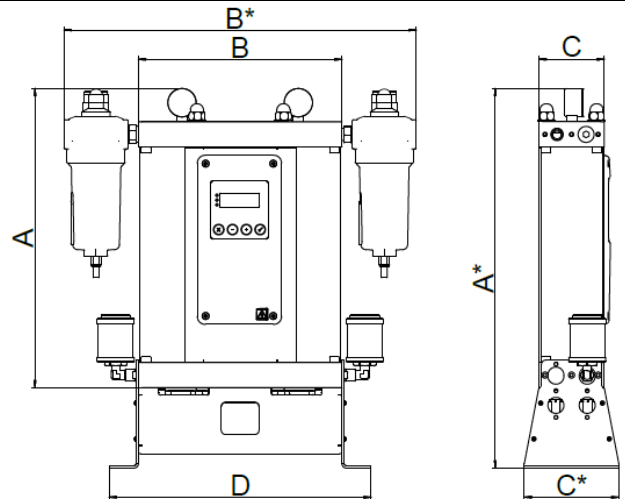

OPERATING PRESSURE

[bar]	4	5	6	7	8	9	10	11	12	13	14	15	16
[psi]	58	72	87	100	115	130	145	160	174	189	203	218	232
C _{OP}	0,63	0,75	0,88	1	1,13	1,25	1,38	1,50	1,63	1,75	1,88	2,00	2,13

OPERATING TEMPERATURE

[°C]	25	30	35	40	45	50	[°C]	-25	-40	-70
[F]	77	86	95	104	113	122	[F]	-13	-40	94
C _{OT}	1	1	1	0,97	0,87	0,80	C _D	1,1	1	0,7

MAINTENANCE

For maintenance, please follow instructions specified in operating manual. Check dryer operation weekly.

Typical service interval:

- Filter elements: every 12 months in operation or sooner if required
- Silencers, valve components: every 24 months in operation or sooner if required
- Adsorbent, valve components, silencers: every 48 months in operation or sooner if required

INFORMATION IN THIS DOCUMENT IS SUBJECT TO CHANGE WITHOUT NOTICE

	Our quality management system is certified by BUREAU VERITAS in conformity with ISO 9001:2015 Reg. number: 200285
---	--