

R12MD – R38MD

Modular regulators,
suitable for compressed air



FEAURES

Diaphragm pressure regulator, standard version inlet pressure up to 20 bar (290 psi).

Inlet and outlet connections 1/2" - F and 3/8" - F in the body.

Outlet pressure is controlled by a rubber diaphragm.

The main valve is balanced.

Modular design to couple with same series: filter and lubricator.

Holes for wall mounting.

Pressure regulation knob with lock system.
Overpressure relieving function.

The product complies with the directive 2014/68/EU PED.

Available on request:
ATEX 2014/34/EU
EAC-EX TP TC 012/2011 versions for the Russian market.

Available units composed of:
Filter + Regulator + Lubricator.

SPECIFICATIONS

Regulator weight: ~0.7 kg (~1.54 lb)

Standard version operating temperature: -10 °C ÷ +50 °C (+14 °F ÷ +122 °F)

Main valve leakage classification: VI (bubble tight)

Flow coefficient: Kv= 2.99

G1/4 port for outlet pressure gauge on both sides

MATERIALS

Body: aluminium casting

Bonnet: PA 6 / POM

Adjusting spring: C85 (not in contact with the fluid)

Main valve spring: C85

Diaphragm: NBR

O-Ring: NBR

Main valve gasket: NBR

ACCESSORIES

Ring-nut for panel mounting

Bracket + ring-nut for wall mounting (10 pcs)

Not relieving version for gas

Gauge

SPARE PARTS

Complete kit: assembled diaphragm, main valve, o-ring, net filter

flow charts

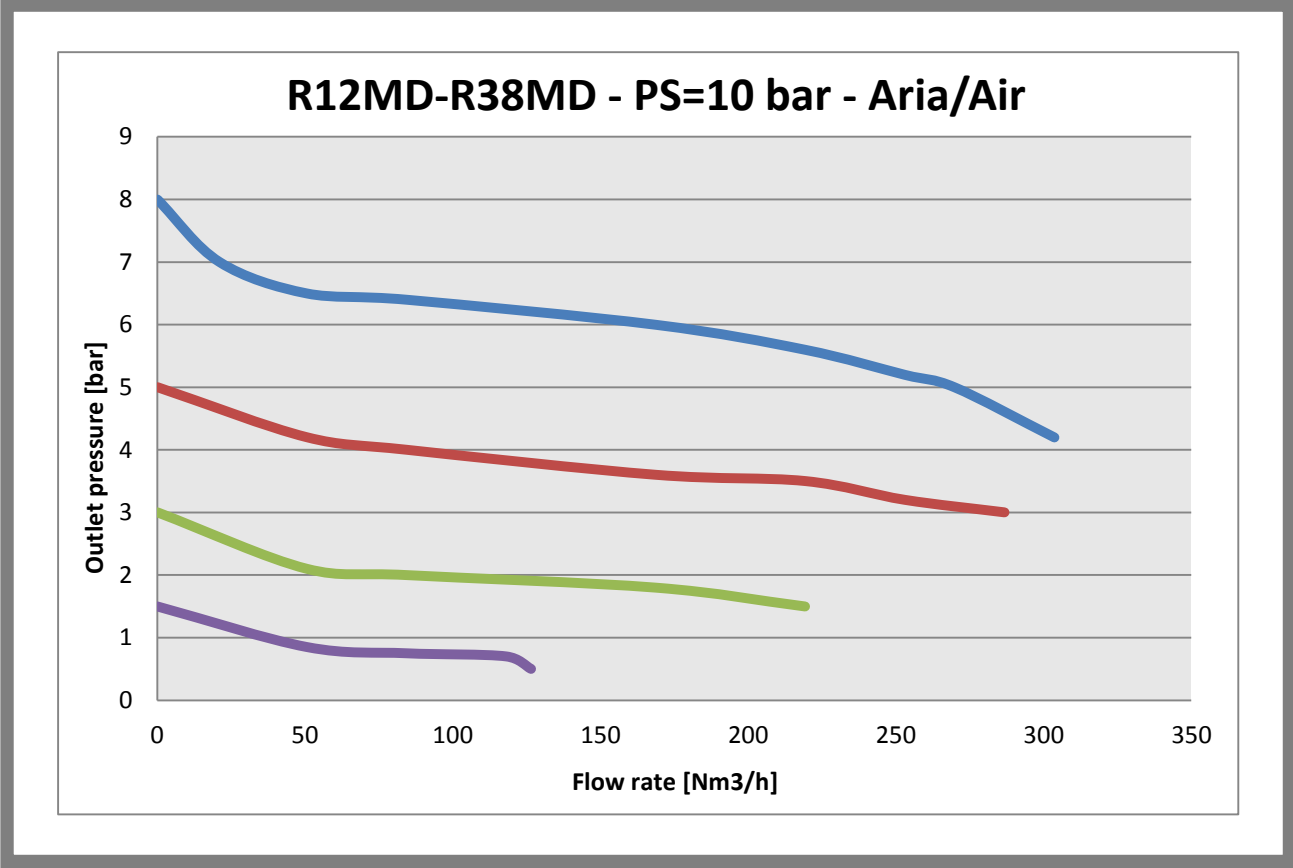

generating the product code

R12MD - R38MD			
AA BB CC DD E F GG			
AA	Attacchi / Connections	L0	R38MD G3/8-F
		P0	R12MD G1/2-F
BB	Pressione d'ingresso / Inlet pressure	C0	20 bar
CC	Intervallo d'uscita/ Outlet range	A0	0,2 - 1,5 bar
		B0	0,3 - 3 bar
		D0	0,8-8 bar
		E0	1,5-15 bar
DD	Tipologia di fluido / Fluid type	01	Relieving
		98	EPDM
		99	FPM
		97	NBR
E	Pilotato / Pilot operated	N	Non pilotato
		P	Pilotato
F	Marchiato / Marked	I	ID
GG	Accessori/Accessories	00	Nessun accessorio

CODE COMPOSITION EXAMPLE

512# L0 C0 D0 01 N I 00

512#: Modular LL regulator

L0: Connections G 3/8 – F

C0: Maximum inlet pressure 20 bar

D0: Outlet pressure range 0,8 – 8 bar (11,6 – 116 psi)

01: Relieving version

N: Not dome loaded

I: Insert Deal

00: No accessories

technical drawings (all dimensions in mm)

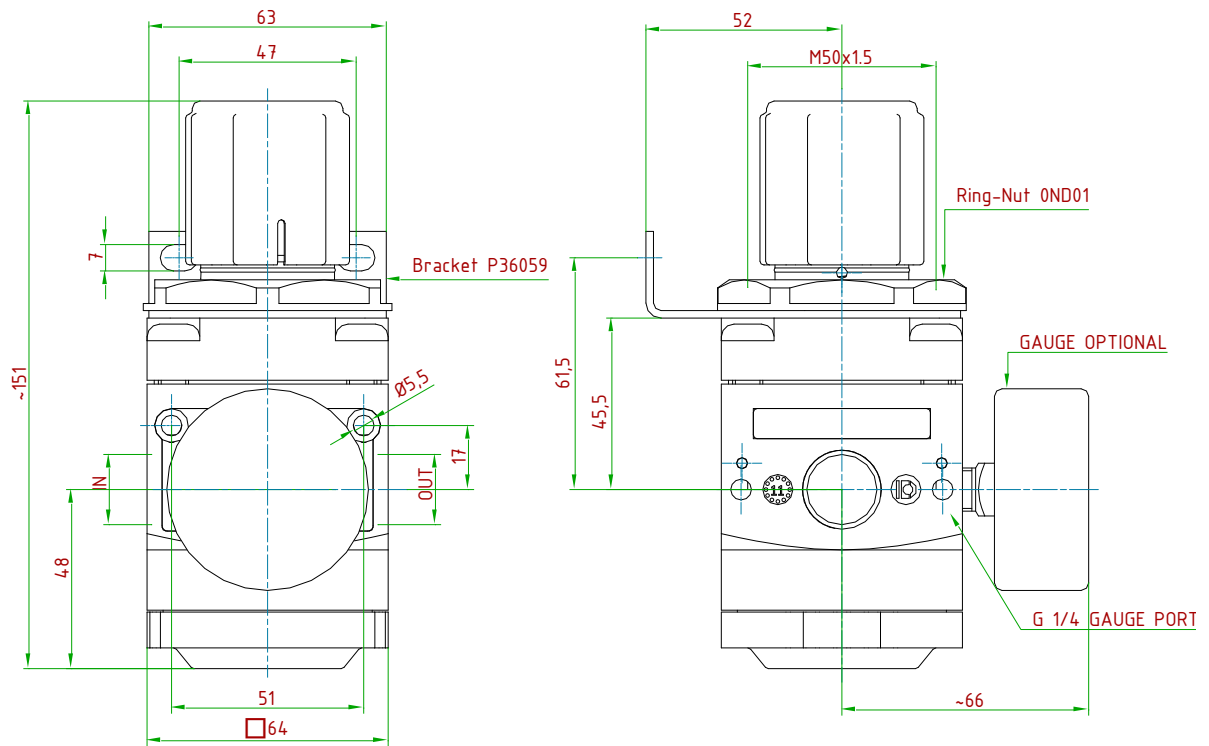

TYPE	IN/OUT	OUTLET PRESSURE [bar]	GAUGE CODE	GAUGE RANGE [bar]
R38 MD 3/8" GF	G 3/8" -F	0.2÷1.5	0ABNAB19	0÷2.5
R12 MD 1/2" GF	G 1/2" -F	0.3÷3	0ABNAB20	0÷6
R38 MD 3/8" NPTF	3/8" NPT-F	0.8÷8	0ABNAB22	0÷16
R12 MD 1/2" NPTF	1/2" NPT-F	1.5÷15	0ABNAB23	0÷25

ID Insert Deal Srl

Strada dei Boschi, 40
20852 Villasanta (MB) Italia
tel. +39 039 302035
info@idinsertdeal.com
www.idinsertdeal.com

ID Insert Deal si riserva il diritto di cambiare le specifiche del prodotto senza preavviso.
ID Insert Deal reserves the right to change and/or modify product specifications without prior notice.

Insert Deal non si assume alcuna responsabilità per la scelta, uso e manutenzione di qualsiasi prodotto. La responsabilità per l'ideale scelta, uso e manutenzione di qualsiasi prodotto ID rimane interamente a carico dell'acquirente.
Insert Deal does not assume responsibility for selection, use and maintenance of any products. Responsibility for proper selection, use and maintenance of any ID products remains entirely to the purchaser.

Riproduzione vietata. Tutti i diritti riservati; nessuna parte del presente documento può essere riprodotta senza autorizzazione di ID Insert Deal Srl.
Reproduction forbidden. All rights reserved; the hereby document can't be reproduced, also partially, without the authorization of ID Insert Deal Srl.

REGOLATORE DI PRESSIONE_512(R12MD-R38MD)_EN_03



Azienda con sistema di gestione qualità certificato.
certificato N° 50 100 9191
Company with certificated quality management system.
certificate N° 50 100 9191